

## Denoising Medical Images using Q-Shift Complex Wavelets

Jayanthi S<sup>1</sup>, H. Ranganathan<sup>2</sup>

<sup>1</sup>Sakthi Mariamman Engineering College, India, jayanthijagan@gmail.com

<sup>2</sup>Rajiv Gandhi College of Engineering, India, ranlal@yahoo.com



**Abstract :** In this paper, we present a method for denoising medical images using Quarter-shift Dual Tree complex wavelet transform. The Q-shift complex wavelets provide a high degree shift invariance and good directional selectivity in filtering signals with more than one dimension. Denoising using these shift-invariant wavelet transforms achieves better performance. The Q-shift DTCWT filters provide linear phase and a tight frame transform, and better selectivity in frequency domain compared to other filters. The QDTCWT brings in only a limited amount of redundancy and is also computationally efficient. All of this is in addition to properties of smoothness and perfect reconstruction. One of the direct applications of denoising medical images is to aid in diagnoses by improving the visual quality of the image.

**Key words :** CT image, Denoising, MRI, Q-Shift dual tree complex wavelet.

### INTRODUCTION

The necessity for denoising of medical images is self-evident. A variety of modern medical diagnoses depend on digital imaging techniques like the MRI and CT scans. Hence a clear motivation for exploring methods to denoise medical images is to aid in diagnoses that depend on the quality of such images. Denoising will also be a required predecessor to advanced processing like segmentation and registration. These have a variety of applications in anomaly detection, pattern recognition and assisted-surgery planning.

The quality of images obtained for medical diagnoses depend on several factors. For example, the dosage of radiation applied during image acquisition affects the quality of CT scan images to an extent. If we attempt to minimize exposure of the patient to these radiations, it could lead to more noise being captured. Noise can also be caused by the various non-linear components, the operating conditions and by the movement of patient during the image acquisition procedure.

The Discrete Wavelet Transform (DWT) is widely used in signal processing. One of the most common applications is compression. However, the lack of directional selectivity and shift variance limit its direct adoption for other tasks such as denoising, especially in cases of multidimensional signals, here images. Another

disadvantage is poor reconstruction properties of the DWT due to lack of phase information. In this work we explore alternative techniques that could perform better for the application in hand, i.e. denoising medical images. We propose a method based on q-shift complex wavelet transform and we have presented the experimentation results in this paper.

The rest of the paper is organized as follows: Section 2 describes the dual tree complex wavelet transform from which the q-shift wavelet transform is derived. Section 3 discusses briefly the q-shift complex wavelet which forms basis for the method to denoise medical images proposed here. Section 4 describes the method itself. The results of the proposed method for denoising medical images are presented in Section 5.

### DUAL TREE COMPLEX WAVELET TRANSFORM

The Dual-tree complex wavelet transform (DTCWT) is superior to the DWT for several reasons, especially for image processing applications like denoising, edge detection, etc. One of the main advantages of the DTCWT is the possibility of perfect reconstruction of the input. The undecimated form of the discrete wavelet transform is computationally expensive and higher output redundancy makes further processing also expensive. Due to the non-redundant property, the DWT has the disadvantages of shift variance, directionality and lack of phase information. The DTCWT introduces moderate redundancy and overcomes these drawbacks by using analytic filters instead of real filters as in the case of DWT.

These properties of the DTCWT have led to it gaining popularity over the decimated discrete wavelet transform (DWT). Dual-tree complex wavelet transform (DTCWT) by Kingsbury [4] is one of the pioneering works in wavelet transform related signal processing. Fig. 1 is based on the same work in [4]. A dual tree of wavelet filters in parallel is used to generate complex coefficients by separately obtaining the real and imaginary parts. It has limited redundancy,  $2^m:1$  for an  $m$ -dimensional signal, therefore an 4:1 order redundancy for images, images being 2 dimensional signals.

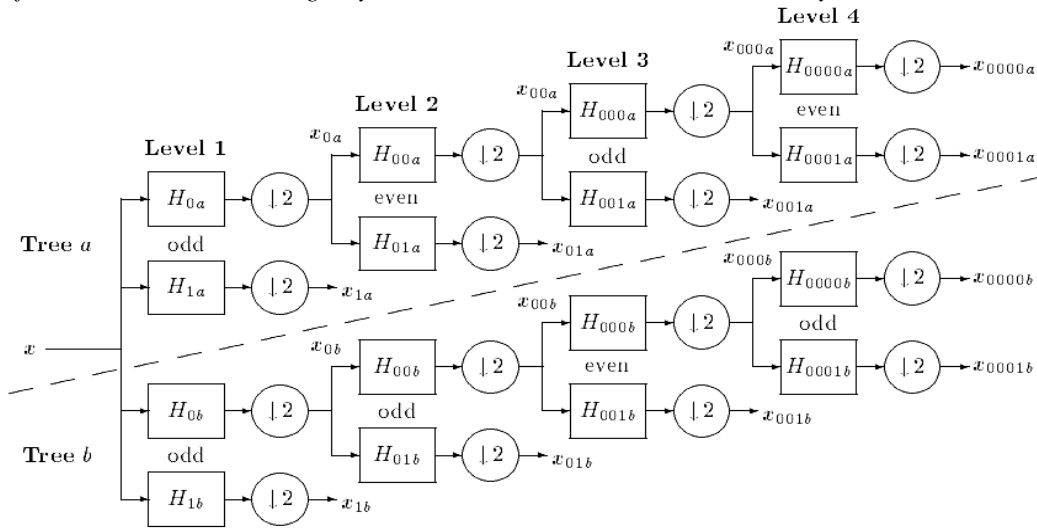

Fig. 1: Analysis filter bank structure of the DTCWT

It has also been shown that shift invariant transforms perform better [8], especially in the case of multidimensional signals.

$$\Psi(t) = \Psi_h(t) + j \Psi_g(t) \tag{1}$$

$\Psi(t)$  is the complex wavelet that is the sum of two separable real valued wavelets. These were developed by Selesnick et al in [1] and [7]. The following discussion is derived from their work in [1]. The complex function  $\Psi_h(t) + j \Psi_g(t)$  is analytic (for  $\omega < 0$ , the Fourier transform is non-existent) and hence the pair of wavelets  $\Psi_h(t)$  and  $\Psi_g(t)$ , are an approximate Hilbert transform pair.

For images, which are basically two-dimensional signals, the filter banks are applied to the rows and columns of the image and the wavelet can be represented by

$$\Psi(x, y) = \Psi(x) \Psi(y) \tag{2}$$

where each of  $\Psi(x)$  and  $\Psi(y)$  are complex wavelets as in (1) above. In effect this the  $\Psi(x, y)$  can be expressed as follows,

$$\begin{aligned} \Psi(x, y) &= [\Psi_h(x) + j \Psi_g(x)] [\Psi_h(y) + j \Psi_g(y)] \\ &= \Psi_h(x)\Psi_h(y) - \Psi_g(x)\Psi_g(y) \\ &\quad + j [\Psi_g(x)\Psi_h(y) + \Psi_h(x)\Psi_g(y)] \end{aligned} \tag{3}$$

From the above equation, the real part of the complex wavelet can be obtained as the sum of two separable wavelets as follows,

$$\text{real} \{ \Psi(x, y) \} = \Psi_h(x)\Psi_h(y) - \Psi_g(x)\Psi_g(y) \tag{4}$$

$\Psi_h(x)\Psi_h(y)$  is a two dimensional real wavelet transform. It is implemented using the filters  $H_{0a}, H_{1a}$ . Similarly

$\Psi_g(x)\Psi_g(y)$  is also a two dimensional real separable wavelet transform, and it is implemented using the filters  $H_{0b}, H_{1b}$ . These are part of tree structure similar to the one depicted in Fig. 1, the filters are linear phase and the delays vary slightly.

The filters used in the two transforms are different but they are such that there is perfect reconstruction and the transform is analytic. To be specific, the delays of  $H_{0b}$  and  $H_{1b}$  are off by one sample from those of  $H_{0a}$  and  $H_{1a}$ . This is easily achieved using short odd length filters in one tree and even length filters in the other.

The dual tree structure is used to decompose the input image into the complex coefficients with what is called the analysis filter bank. The outputs of each tree are down sampled at every stage. The signal is reconstructed by the tree structure called the synthesis filter bank by up sampling and adding the outputs of the two trees during reconstruction. Fig. 1 depicts analysis filter bank of the DTCWT described in the next section.

As noted before one of the main advantages of the complex wavelet transform achieved using the dual tree is the ease and accuracy of reconstruction. The inverse of the transform can be performed by inverting both the real and the imaginary part. The inverse of each of the real DWTs is used to obtain two real signals whose average is the final inverted transform output. Hence the synthesis filter bank follows as similar tree structure as the analysis filter bank (fig. 1) but the structure is mirrored and each of the inverted filtering operation is followed by up sampling and averaging.

Another advantage of the dual tree structure is that the independence of the two trees makes it possible for parallel computation. It is to be noted that the computation at each stage is a simple filtering operation and that only the first stage filters need to be different.

To summarize, the advantages that make DTCWT highly convenient for image processing applications such as denoising are: shift invariance, good directional selectivity especially for 2 dimensional signals, perfect reconstruction using linear phase filters, all of this at the expense of only a 4:1 redundancy for images.

### Q-SHIFT DUAL TREE COMPLEX WAVELET TRANSFORM

One further improvement over the DTCWT is the QDTCWT. A slight drawback of the DTCWT approach is that these linear phase filters must be biorthogonal. It would be convenient to design if the filters are orthogonal. Also the sampling leads to loss of symmetry and the trees end up having slightly different frequency domain responses. These can be overcome without much excess expense by using the QDTCWT.

The QDTCWT is based on a filter with a quarter sample delay apart from the conditions of accurate reconstruction and orthonormality. In effect the 2D q-shift dual tree results in six bandpass sub wavelets of complex coefficients. These have strong and distinct positive and negative orientations at angles of  $\pm 15^\circ$ ,  $\pm 45^\circ$ ,  $\pm 75^\circ$ . Unlike the DTCWT both the trees of the QDTCWT have similar frequency response. There is greater symmetry of sampling in the trees as well. In this work, the filters used in the tree structure are based on the 14-tap linear phase filter prototypes developed in [3] by Kingsbury et al.

### QDTCWT BASED DENOISING OF MEDICAL IMAGES

Complex wavelet transform based methods allow for robust estimation and elimination of noise from images. The following is the method being proposed,

- Decompose the image using the q-shift dual tree complex wavelet transform (QDTCWT) using the analysis filter bank.
- The image is decomposed up to four layers to obtain the complex coefficients.
- Apply soft thresholding to each layer of the image's transform to obtain the new set of the QDTCWT coefficients.
- Compute inverse QDTCWT using the synthesis filter bank to obtain the denoised image.

The algorithm has been implemented in MATLAB. The observations and results of testing are presented in the following section.

### RESULTS

Fig. 2 depicts visually the denoising achieved by different methods. The input image is an MRI section of the axial view of the brain. The actual image is a high resolution image obtained for research purposes. All medical images used during the course of this work were sourced from the brainix database, hosted by osirix as dicom files.

It is clearly perceivable the various degrees of denoising in each case. It can also be observed that the method ensures that no critical information containing feature is lost. Fig. 3 depicts a comparison of a simple hard thresholding and the soft thresholding methods. From both of these figures, it is evident that the proposed QDTCWT method has achieved the best visually perceptible results in denoising.

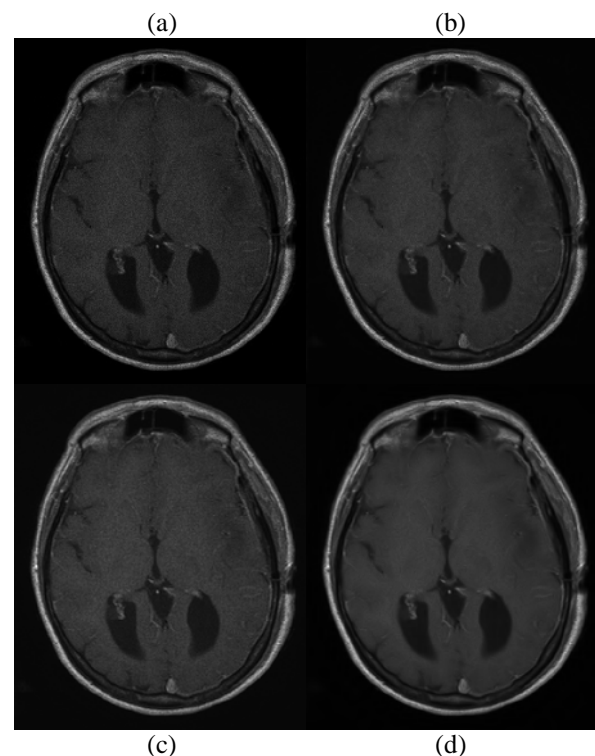

Fig. 2: (a) Noisy input medical image: an axial view of the brain through MRI (b) Denoised using 2D DWT (c) Denoised using DTCWT (d) Denoised using the proposed QDTCWT

Fig. 4 quite clearly indicates that the QDTCWT provides superior PSNR values for the same range of thresholding values for the image used in Fig. 2 above. A similar trend

was observed for all other images which were tested with. While the thresholding is the key operation that eliminates the noise, it is also not desirable to have very high thresholding values because the averaging effect could lead to blurring and loss of actual data. This is indicated by the dipping PSNR values of the upper curve as the thresholding value increases.

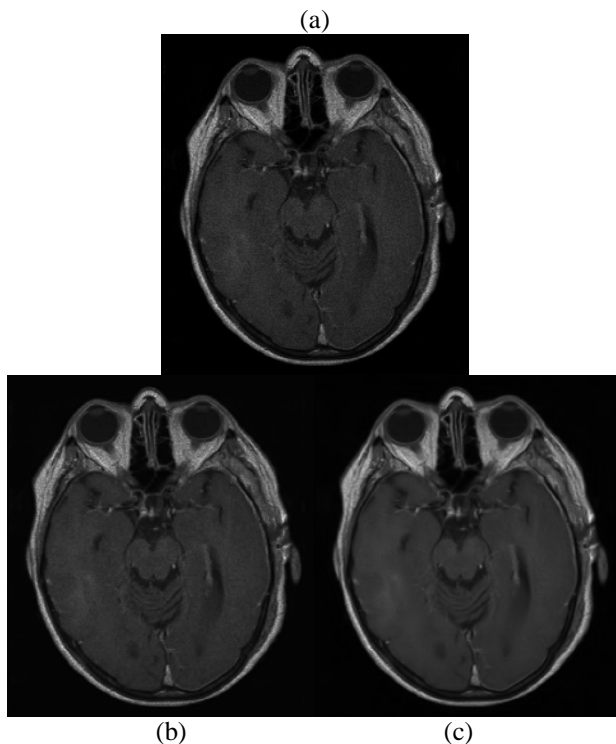

Fig. 3: (a) Noisy input medical image: another axial view of the brain (b) hard threshold denoised (c) Denoised using the proposed soft thresholding on QDTCWT coefficients

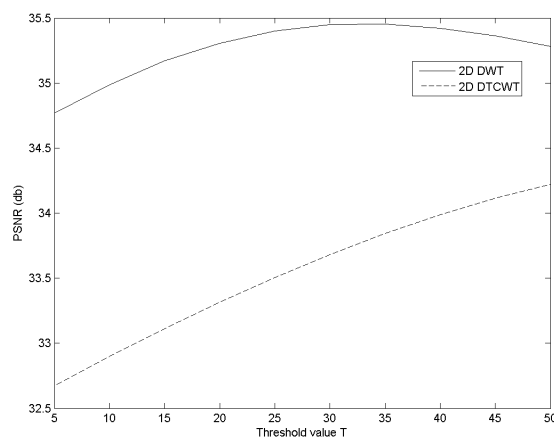

Fig. 4: PSNR vs. soft threshold value

It is to be noted that the optimal thresholding can be achieved through this method as well. This implementation and testing were performed on a moderate configuration computer and hence we can claim that the computation involved is also not very heavy.

## CONCLUSION

In this work we have explored denoising medical images using the q-shift dual tree complex wavelet transform. We have implemented an algorithm based on soft thresholding to achieve denoising. We can effectively take advantage of properties of shift invariance, directional selectivity and reconstruction for the current application of medical image denoising. We can safely conclude that QDTCWT can be used to achieve better denoising performance in medical images without losing crucial information contained in the images. We have also argued that the computation is not very heavy. The QDTCWT also allows for the possibility of other medical image processing tasks such as segmentation, enhancement.

## REFERENCES

- [1] Selesnick, Ivan W., Richard G. Baraniuk, and Nick C. Kingsbury. "The dual-tree complex wavelet transform." *Signal Processing Magazine, IEEE* 22.6 (2005): 123-151.
- [2] Daubechies, Ingrid. *Ten lectures on wavelets*. Vol. 61. Philadelphia: Society for industrial and applied mathematics, 1992.
- [3] N G Kingsbury: "Complex wavelets for shift invariant analysis and filtering of signals", *Journal of Applied and Computational Harmonic Analysis*, vol. 10, no 3, May 2001, pp. 234-253.
- [4] Kingsbury, Nick G. "The dual-tree complex wavelet transform: a new technique for shift invariance and directional filters." *Proc. 8th IEEE DSP workshop*. Vol. 8. Utah, 1998.
- [5] Mallat, Stephane G. "A theory for multiresolution signal decomposition: the wavelet representation." *Pattern Analysis and Machine Intelligence, IEEE Transactions on* 11.7 (1989): 674-693.
- [6] Simoncelli, Eero P., et al. "Shiftable multiscale transforms." *Information Theory, IEEE Transactions on* 38.2 (1992): 587-607.
- [7] Selesnick, Ivan W. "Hilbert transform pairs of wavelet bases." *Signal Processing Letters, IEEE* 8.6 (2001): 170-173.

**International Journal of Science and Applied Information Technology (IJSAIT)**, Vol. 3 , No.3, Pages : 36 - 40 (2014)  
*Special Issue of ICCET 2014 - Held during July 07, 2014 in Hotel Sandesh The Prince, Mysore, India*

- [8] Kingsbury, Nick. "Shift invariant properties of the dual-tree complex wavelet transform." Acoustics, Speech, and Signal Processing, 1999. Proceedings., 1999 IEEE International Conference on. Vol. 3. IEEE, 1999.
- [9] Kingsbury, Nick. "Design of q-shift complex wavelets for image processing using frequency domain energy minimization." Image Processing, 2003. ICIP 2003. Proceedings. 2003 International Conference on. Vol. 1. IEEE, 2003.