

# Conception of Circular Sector Microstrip Antenna and Array

**A.Dalli, L. Zenkouar**

Laboratoire d'Electronique et de Communications  
 Ecole Mohammadia d'Ingénieurs – EMI,  
 Université Mohammed V-Agdal Rabat, Morocco

**S. Bri**

Ecole Supérieure de Technologie - EST  
 Université Moulay Ismail  
 Meknes, Morocco

## ABSTRACT

This paper presents the design of a circular sector microstrip antenna and arrays that could be used in many bands: X or C band. Based on the designed patch antenna, many phased arrays will be simulated using HFSS. The impact of distance between element, number of element and phase will be checked. Obtained results are analyzed.

**Keywords :** Microstrip antenna, Antenna array, Polarization

## 1. INTRODUCTION

With the ever-increasing need for portable computing devices and the emergence of many systems, it is important to design a portable and efficient antenna for communication [1]. The design of an efficient wide band small size antenna, for recent wireless applications, Wi-Fi, Bluetooth, Radar etc., is a major challenge [1-4]. Microstrip patch antennas have found extensive application in wireless communication system due to their advantages such as low profile, conformability, low-cost fabrication and ease of integration with feed networks. Recently, lot of commercially available antennas are used in wireless applications, for the outdoor application helix antenna are used and for the inbuilt integration antenna a

The conducting patch of microstrip antenna can take any shape, but rectangular configurations are the most commonly used [5]. In our study we are interested in circular sector shape, because of their small size compared with other shapes like the rectangular and circular patch antennas and provide circular polarization which is desired in wireless communication.

In this study, several designs of circular sector patch antennas arrays are presented. then array of patch antenna will be designed using theory of array factor. Moreover, these designs are simulated using HFSS. circular sector patch antennas array is achieved in C-Band. This band contains frequency ranges that are used for many satellite communications transmissions, some Wi-Fi devices, some cordless telephones, and some weather radar systems.

This paper is divided into four sections: the first section is devoted to give an overview of the patch antennas and a preface of the important parameters in single element and array. In second section, proposed designs will be presented. In third section, obtained results are analysed. Finally, a brief conclusion is presented in the fourth section.

## 2. THEORY

### 1. Single element

Patch antenna design in C-band and with optimal characteristic is the overall objective of this section. To achieve this overall objective, the primary task is to choose a suitable geometry of the patch for the antenna. The proposed shape is circular sector patch. Circular sector patch antenna structure is shown in Figure 1.

For circular sector patch antenna, the expression of the radius "a" of the patch is [6]:

$$a = \frac{k_{mn}c}{2\pi f_r \sqrt{\epsilon_r}} \quad (1)$$

k<sub>mn</sub> is the zero of the equation J'(k<sub>mn</sub>) = 0. J is the Bessel function.

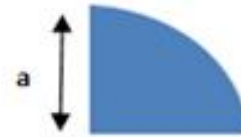

**Figure 1:** Geometry of both rectangular and circular sector patch antennas

The dielectric thickness is h, dielectric constant is ε<sub>r</sub>, light speed is c, resonant frequency is f<sub>r</sub>, wavelength is λ.

### 2. Antenna array

#### a. Linear Array

A uniform array is defined by uniformly-spaced identical elements of equal magnitude with a linearly progressive phase from element to element.

The AF can be obtained by considering the individual elements as point (isotropic) sources. If the elements are of any other pattern, the total field pattern can be obtained by simply multiplying the AF by the normalized field pattern of the individual element.[4]

$$AF = \frac{\sin(N\psi/2)}{N\sin(\psi/2)} \quad (2)$$

The function ψ is defined as the array phase function and is a function of the element spacing, phase shift, frequency and elevation angle:

$$\psi = \beta d \cos\theta + \alpha \quad (3)$$

b. Planar array

Planar arrays provide directional beams, symmetrical patterns with low side lobes, much higher directivity (narrow main beam) than that of their individual element. In principle, they can point the main beam toward any direction.

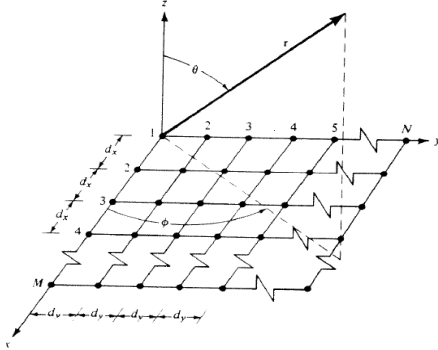

Figure 2: Planar antenna array

If N such arrays are placed at even intervals along the y direction, a rectangular array is formed. We assume again that they are equi-spaced at a distance dy and there is a progressive phase shift  $\beta y$  along each row. We also assume that the normalized current distribution along each of the x-directed arrays is the same but the absolute values correspond to a factor of n (n=1,...,N). Then, the AF of the entire MxN array is [4]

$$AF(\theta, \phi) = \left[ \frac{1}{M} \frac{\sin(M\frac{\psi_x}{2})}{\sin(\frac{\psi_x}{2})} \right] \cdot \left[ \frac{1}{N} \frac{\sin(N\frac{\psi_y}{2})}{\sin(\frac{\psi_y}{2})} \right] \quad (4)$$

Same as linear array, the functions  $\psi_x$  and  $\psi_y$  are defined as the array phase function and are a function of the element spacing, phase shift, frequency and elevation angle:

$$\psi_x = d_x \sin\theta \cos\phi + \beta_x \quad (5)$$

$$\psi_y = d_y \sin\theta \sin\phi + \beta_y \quad (6)$$

Actually, in order to make fair comparison, the same substrate used in single element ( $\epsilon_r = 10.2$  and thickness  $h=0.127$  cm), is used for all proposed arrays.

c. Circular array

The four elements antenna array proposed in the article will be considered as a circular array (figure 3). To calculate the array factor, we will refer to that calculated in [5] for a circular array.

$$AF(\theta, \phi) = \sum_{n=1}^N I_n e^{j(k a \sin\theta \cos(\phi_n - \phi_0) + \alpha_n)} \quad (7)$$

$\Phi_n$ : The angular position of element n

$\alpha_n$ : The phase of excitation of element n

$I_n$ : The amplitude of excitation of element n

N: Number of element array

From (7), the AF is a function of the geometry of the array and the excitation phase, by varying the separation and/or the

phase between the elements, the characteristics of the total field of the array can be controlled.

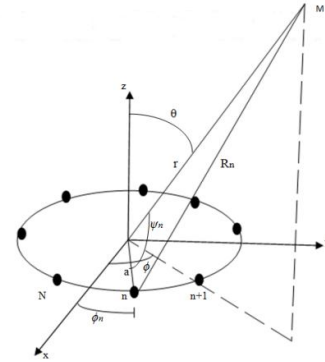

Figure 3. circular antenna array

We presented in this section the basic notions of antenna arrays. These notions are used to predict the elements to be taken into consideration for the design of an array antenna to have desired characteristics. But the calculation of the radiation characteristic of an antenna array is very complex, even for the simplest array, which justifies the use of HFSS simulator method for the synthesis antenna.

3.DESIGN

1. Single element design

Figure 1 shows the architecture of the proposed antenna. It is a circular sector antenna fed by microstrip line. The used substrate is RO3200 ( $\epsilon_r = 10.2$ ), thickness  $h=0.127$  cm. The angle and radius of circular sector patch are respectively  $\alpha = 90^\circ$  and  $a=1$ cm. [6]

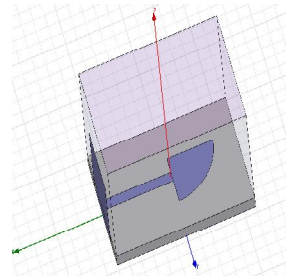

Figure 4: Circular sector patch antenna designed in HFSS fed by microstrip line

2. Array design with parallel feed

The antenna arrays will be designed using HFSS. The software enables to compute antenna array radiation patterns and antenna parameters for designs that have analyzed a single array element. HFSS models the array radiation pattern by applying the ‘‘array factor’’ on the single element’s pattern.[12] By following this methodology we can design planar and linear array as shown in figure 5.

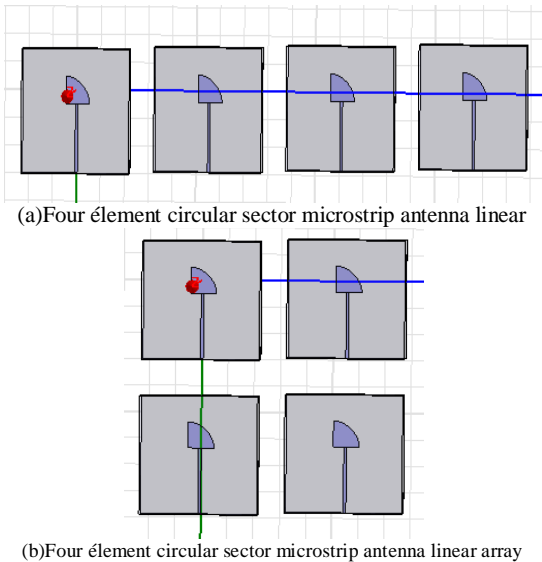

Figure 5: Some designed arrays with parallel feed using HFSS (a) linear (b) planar

3. Array design with serial feed

In this paper, the chosen radiating element is circular sector patch studied in [3], the radius of the patch is  $a = 10$  mm (Figure 1). We will study array of 2 and 4 patch using the substrate FR 4 (permittivity  $\epsilon = 4.4$ ,  $\tan\delta = 0.02$  and thickness  $h$ ) which is widely used for patch antennas, RO3006 permittivity  $\epsilon = 6.5$ ,  $\tan\delta = 0.0025$  and thickness  $h$ ) and RO3210 substrate (permittivity  $\epsilon = 10.2$ ,  $\tan\delta = 0.003$  and thickness  $h$ ) was used in [6].

RO3210 and RO3006 was chosen because they are based on polytetrafluoroethylene (PTFE) which are widely used because of their electrical and mechanical characteristics.[1] minimum cost and permit to have a miniature antenna with a minimum loss. In references, we cited some use of this substrate in emerging application [8,9].

The distance between the elements was chosen in the interval  $(0.4\lambda, 0.9\lambda)$ , the patches are fed by microstrip lines. The length and thickness were chosen so as to obtain optimum performance of our array.

a. Array of 2 elements

Figure 6 shows the proposed 2 elements array (1x2). We opted for feeding through a network of microstrip line in the form of T excited by source  $50 \Omega$  studied in the literature [11,12]. In this way the two patches will have the same excitation.[7]

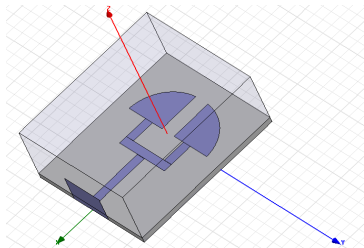

Figure 6: Circular sector patch antenna array with T feed (1x2)

b. Array of 4 elements

For this array we opted for feeding network in the form of H excited by a source to  $50\Omega$  studied several times in the literature [13-15]. The advantage of this feeding method is that it allows having the same excitement phase and amplitude at the output as confirmed in [16].

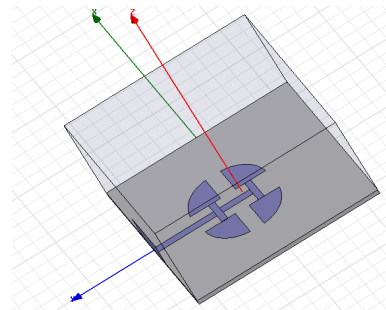

Figure 7: Circular sector patch antenna array with H feed (2x2)

4. RESULTS AND ANALYSIS

1. Single element results

a. Effect of substrate for circular sector antenna

Changing substrate has a major effect on antenna even the return loss. For RO3200 ( $\epsilon = 10.2$ ) antenna resonate for (4.48 GHz, 5.27GHz and 7.8 GHz) with maximum return loss of -15dB. For RO3006 ( $\epsilon = 6.4$ ) antenna resonant frequencies (4.87GHz and 7.7 GHz) and return loss is -17dB but for FR4 ( $\epsilon = 6.4$ ), antenna has one resonant frequency (6.6GHz) with a good return loss -22dB.

Hence we deduce that by using substrate with high permittivity changed the nature of the antenna: We switched from a broadband antenna with good reflection coefficient (-22dB) to a multiband frequency antenna that can be used to cover C-Band with reflection coefficient  $S_{11} < -10$ dB.

b. Radiating pattern and gain

Radiation pattern in E-plan of circular sector and rectangular microstrip antenna are traced in figure 8:

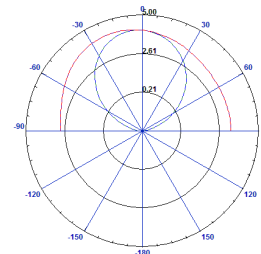

Figure 8: Radiation pattern of circular sector antenna in 4.48GHz

From the simulated results, it is shown that patterns of all antennas are directive and have similar form. The gain of the studied antenna is about 5dB and 5.7dB. So we can deduce that circular sector patch didn't change the gain if we compare it to rectangular patch.

This limitation in generated gain will be overcome in the second section by using arrays.

2. Array with parallel feed analysis

a. Influence of inter-element distance

In this subsection, we analyze the influence of the inter-element distance  $d$  on radiation pattern, as illustrated in Figure 9 given below. The studied array is composed of 4 elements in linear position and feeding phase is  $45^\circ$  based on circular sector microstrip antenna.

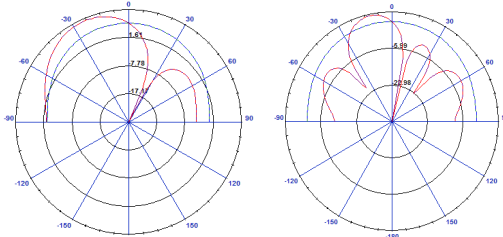

**Figure 9:** Influence of changing inter-element spacing for circular sector and rectangular microstrip antenna

It can be observed clearly that the beam widths of all major lobes became narrow and the number of minor lobes increases, when the inter-element distance increases. In addition, it can be found that for the all arrays the directions of major lobes are not fixed, while the distance is varied. Furthermore it is also observed that arrays provide beam steering for both patch shape.

b. Influence of element number

The table 1 show generated gain for circular sector and rectangular microstrip antenna array for different number of elements ( $N= 4 ; 6 ; 10 ; 14$ ).

For array with larger the number of elements, the total gain increase for both arrays. But if we compare realized gain for rectangular and circular sector antenna array. We can deduce that gain of circular sector antenna array is superior to gain of rectangular microstrip antenna arrays.

**Table 1:** Gain for circular sector microstrip antenna array for  $N= 4 ; 6 ; 10 ; 14$

Number of element	Gain for Circular sector patch (dB)
4	10
6	12
10	14.11
14	15.56

But we cannot increase number of element to infinite number, it's important to take in consideration the dimension of array. [17]

3. Array with serial feed analysis

Referring to the parameters outlined in the previous section, we simulated networks 1x2 and 2x2 using HFSS for FR4, RO3006 and RO3210 substrates. In this section we present the results for the reflection coefficient, radiation pattern. Performances of antennas studied are compared with literature.

a. Results for the 1x2 array

Figure 10 shows the reflection coefficient for the 1x2 network for both RO3210 and FR4 substrates. The network using the FR4 will be called "antenna 1", the one using RO3006 will be called "antenna 2" and antenna using RO3210 will be called "antenna 3".

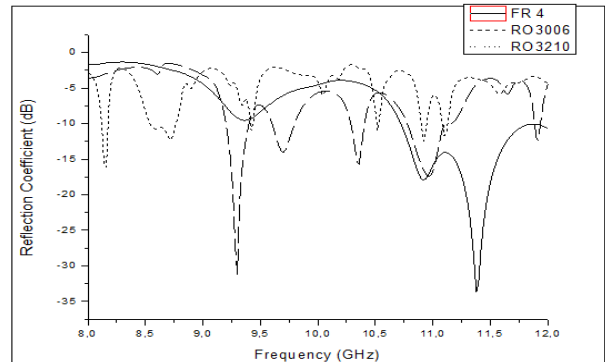

**Figure 10** Reflection coefficient of the 1x2 array for FR4, RO3006 and RO3210 substrate at X Band

Figure 10 gives the reflection coefficient of antenna 1 and 2, both antennas are not radiating in the same band: for antenna 1, showing that a wide impedance bandwidth of 14.5%, ranging from 11.6 to 13.4 GHz, for  $S_{11} < -10\text{dB}$  is achievable and a maximum to -26dB. In comparison with antenna 2 using a substrate with a high permittivity, the antenna radiate in lower frequency, it's a dual band antenna 8.25 and 8.7 GHz with a narrow bandwidth (2%). Hence we deduce that the change of the substrate has completely changed the nature of the antenna: We switched from a broadband antenna to a dual-band frequency antenna and with different resonances frequency..

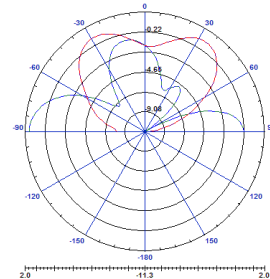

**Figure 14:** Radiation pattern of the antenna 2 at 8.7 GHz

In figure 14, the radiation pattern is traced for antenna 1 at central frequency 12.2 GHz. The Figure shows that the simulated radiation pattern is bi-directional at  $0^\circ$  plane. The simulated gain could attempts 6dB; the gain is impacted because of mutual effect of the patches and interference with feeding network. This gain could be augmented if we increase

the distance between elements, but in the other side the directivity of antenna will decrease and dimension of our antenna array will be bigger. We noted also that gain does not depend on substrate; we had the same gain for both antennas.

**b. Results for the 2x2 array**

Figure 11 shows the reflection coefficient for the 2x2 network for both RO3210 and FR4 substrates. The network using the FR4 will be called "antenna 4" , the one using RO3210 will be called "antenna 5" and antenna using RO3210 will be called "antenna 6"

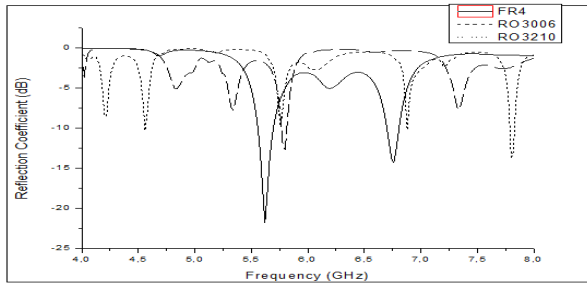
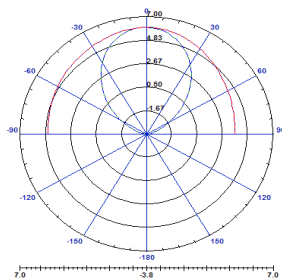

**Figure 11:** Reflection coefficient of the 2x2 network for FR4, RO3006 and RO3210 substrate at C Band

Antennas 3 and 4 were simulated in HFSS to see the effects of changing substrate and the impact of permittivity. From Figure 11, we can note that the antenna 3 has a broadband which is 16,3%, from 5.3 GHz to 6.3 GHz with a coefficient less than -10 dB and maximum to -26 dB. Now for the antenna 4, there is a dual band, the antenna 4 can resonate in 4.3 GHz and 4.66 GHz but the bandwidth is narrow (1%). Hence the conclusion is the same as exposed previously we deduce that the change of the substrate has completely changed the nature of the antenna: We spent a broadband antenna to an antenna with dual-band and different resonance frequencies.

The impact of number of element could be analyzed if we compare figure 6 and 9. From figure 6-a and 9-a, the traced reflection coefficient shows that both antenna have wide bandwidth, in the other side we noted also that by doubling the number of radiating elements from 2 to 4, the resonant frequency has been divided by two for both antennas. From figure 6-b and 9-b, both antennas are dual band and for 4-element array the resonance frequencies are lesser than for 2-elements array.

Then we will trace radiation pattern for antenna 3 in resonant frequency.



**Figure 12:** Radiation pattern of antenna 6 at 4.68 GHz

Figures 12 shows the radiation patterns of antennas 3 for the resonance frequencies. It is noted that the diagrams represented a principal directional lobe; we also noted the absence of secondary lobes. The maximum measured gain at resonance frequency for antennas 3 and 4 is 9 dB, so when we doubled the number of elements from 2 to 4, the gain increased by 2dB but this gain is lower than gain obtained for arrays (12dB) in literature but it still an interesting result for the dimension of the proposed antenna, and the comparison is achieved in section 4.3.

**5.CONCLUSION**

In this paper, a detailed study of circular sector micro-strip antenna was presented. We demonstrate that changing changing substrate can modify the nature of the antenna: We switched from a broadband antenna with good reflection coefficient (-22 dB) to a multiband frequency antenna that can be used to cover C-Band with reflection coefficient  $S_{11} < -10$  dB.

In the second part of paper, we used antenna array to overcome the problem of low gain, two kind of arrays based on circular sector microstrip antennas were designed.

First array is with parallel feed, proposed arrays are compatible for C- band. The gain of patch antenna was improved for both shapes using array techniques (10 dB for 4 elements) and (14 dB for 10 elements). From comparison with literature [14-16], we proved the ability of using circular sector patch antenna array with same performance of rectangular patch with interesting dimension and circular polarization.

Then, we studied array with serial feed. The impact of number of radiating element was analysed, we demonstrate that when we doubled the number of elements from 2 to 4, the gain increased by 2dB and the resonant frequency has been divided by two. we noted that our antennas have interesting geometric characteristics. Simulations show that each antenna can be used for a resonant frequency included in the 4-12 GHz band with a good reflection coefficient. However we noted that there is still work to be done to improve the gain of these antennas to achieve 10 dB for an array with two elements and 12 dB for a 4-element array.

**REFERENCES**

- [1]. D.H.Schaubert, D.M.Pozar, A.Adrian "Effect of Microstrip Antenna Substrate Thickness and Permittivity: Comparison of Theories with experiment" IEEE Transactions on Antennas and Propagation, Vol. 31, No. 6, June 1989 pp83-90
- [2]. R.J. Mailloux, J.F.McIlvenna and N.P.Kernweis "Microstrip Array Technology" IEEE Transactions on Antennas and Propagation, Vol.29, NO.1, January 1981 pp 25-37
- [3]. D.M.Pozar « Microstrip Antennas » Proceeding of the IEEE, Vol. 80, No 1, January 1992
- [4]. T.C. Cheston, J.Frank "Phased Array Radar Antenna" Mc Graw Hill Edition 1990
- [5]. C.A. Balanis « Antenna Thoery :Analysis and Design » New York : Wiley 1997
- [6]. A.Dalli, L.Zenkouar and S.Bri "Comparison of circular sector and rectangular patch antenna arrays in C-Band" Journal of Electromagnetic Analysis and Applications, Vol. 4 No. 11, 2012, pp. 457-467

- [7]. A.Dalli, L.Zenkouar, S.Bri "Study of Circular Sector Patch Array Antenna With Two and Four Elements for C and X Band" European Journal of Scientific Research Vol.81 No.2 (2012), pp.150-159
- [8]. Z.Noroozi and F. Hojjat-Kashani "Three-Dimensional FDTD Analysis of the Dual-Band Implantable Antenna for Continuous Glucose Monitoring" Progress In Electromagnetic Research Letters, Vol. 28 No 9, 2012 pp 9-21
- [9]. Nasimuddin Z.N. Chen "Wideband microstrip antennas with sandwich substrate" IET Microwaves, Antennas & Propagation Vol. 2, No. 6, 2008, pp 538-546
- [10]. Online documentation of HFSS on: [www.ansys.com](http://www.ansys.com)
- [11]. M.Shihab, Y.Najjar, N.Dib, M.Khodier "Design of Non Uniform Circular Antenna Arrays Using Particle Swarm Optimization" Journal of Electrical Engineering, Vol. 59, No. 4, 2008, pp 216-220
- [12]. J.H Lu « Broadband Dual-Frequency Operation of Circular Patch Antennas and Arrays With a pair of L-Shaped Slots » IEEE Transactions on Antennas and Propagation Vol 51 No 5 May 2003
- [13]. R. Gardelli, G. La Cono, and M. Albani, « A Low-Cost Suspended Patch Antenna for WLAN Access Points and Point-to-Point Links » IEEE Antenna and Wireless Propagation Letters, Vol. 3, 2004
- [14]. B.Biglarbegian, M.Fakharzadeh, D.Busuioc, M.Ahmadi, S.Nacini "Optimized Microstrip Antenna Arrays for Emerging Millimeter Wave Wireless Applications" IEEE Transactions on antennas and propagation Vol 59 No 5 May 2011
- [15]. D.Sood, G.Singh, C.Tripathi, P.Joshi "Design, Fabrication and Characterization of Microstrip square patch antenna array for X-Band Applications" Indian Journal of Pure & Applied Physics Vol 46 August 2008 pp 593-597
- [16]. H.Legay and L.Shafai "A self-matching widband feed network for microstrip array" IEEE Transactions on Antennas and Propagation Vol 45 No 4 April 1997
- [17]. V.R.Anitha and N.Reddy "Design of an 8x1 square microstrip patch antenna array" International Journal of electronic engineering research Vol .1 Number1 (2009) pp71-77