



## Evolution of Small Scale Solar Pump Using Shape Memory Alloy

Md. Irfan<sup>1</sup>, B. Yeswanth Kumar Reddy<sup>2</sup>, S. Irfan Sadaq<sup>3</sup>, S. Shahar Banu<sup>4</sup>

<sup>1,3,4</sup>Assistant Professor, Mechanical Engineering Department, Muffakham Jah College of Engineering & Technology, Hyderabad, Telengana, India - 500034

<sup>2</sup>Teaching Assistant, Mechanical Engineering Department, JNTUA College of Engineering, Pulivendula, YSR District, Andhra Pradesh, India – 516390

mdirfan@mjccollege.ac.in, hai2yeshu@gmail.com, irfan.sadaq@mjccollege.ac.in, ssbanu@mjccollege.ac.in

### ABSTRACT

Electrical power shortage problems are increasing year by year and creating direct impact on farmers. Concept of deriving electrical power from solar radiation started in early 90's itself to get rid of the problems. The concept did not see much of light as water is being proposed to be used as primary working fluid in all solar devices. A device is designed as a part of this project, which utilizes the deformability of the shape memory alloy when it is cold and its reversion to its original shape (when the alloy is heated to above its transition temperature it return to its original length) as the power source for the device. Repetitive thermal cycling causes the strip of material to alternatively elongate and shorten. Thermal cycling over a period of time also trains the alloy to change shape repetitively and accurately with smaller temperature differentials. The device ultimately produces rotary motion, which will be converted into suitable mechanical means for pumping water in absence of conventional electrical power. The outcome of the project is a design of solar pump, which will give a promising solution for a farmer suffering from power shortage problems in summer season.

**Key Words:** Shape Memory Alloy, Thermo-Structural Analysis, NiTi Alloy, Nitinol.

### 1. INTRODUCTION

Concept of deriving electrical power from solar radiation started in early 90's itself to get rid of these problems. This concept didn't see much of light as water is being proposed to be used as primary working fluid in all solar devices. Water is considered to be less reactive fluid as it takes more time to get transform into vapors phase. Due to this reason utilization of solar power is limited to the extent of deriving hot water only instead of steam.

#### 1.1. SHAPE MEMORY ALLOYS

A shape memory alloy (SMA, also known as a smart metal, memory alloy, or muscle wire) is an alloy that remembers its shape, and can be

returned to that shape after being deformed, by applying heat to the alloy. To begin with the properties that are characteristic of shape memory alloys (SMA's) are understood and the same is discussed here. Two main characteristics identify shape memory alloys (SMA's), shape memory effect and pseudo elasticity. By training the SMA's at a given temperature, they can be made to memorize a specific configuration, which can be activated via temperature change or via externally applied load. They can sustain a large amount of strain, suffer no permanent plastic deformation, and recover their original length upon heating.

#### 1.2. Metallurgical Property of NiTi Alloy

Unlike other metallic materials, SMAs undergo large amount of deformation without permanent deformation. Not only they can sustain large deformations, they can recover that strain upon temperature change. This characteristic of SMAs is due to their unique phase transformation mechanism. One type of SMA is Nitinol, which we will use as an example in explaining the unique characteristic of SMAs.

#### Applications of Shape Memory Alloys

Among hundreds of alloys that exhibit the shape memory effect, only two alloy systems, TiNi phase diagram as shown in figure 1 and CuZnAl, have found practical applications. Other alloys are expensive or they exert insufficient force for most applications.

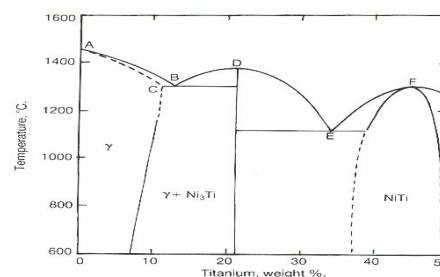

Figure 1: Nickel-Titanium phase diagrams

### 2. PROBLEM DEFINITION

A device is designed as a part of this project, which utilizes the deformability of the

shape memory alloy when it is cold and its reversion to its original shape (When the alloy is heated to above its transition temperature it returns to its original length) as the power source for the device. Repetitive thermal cycling causes the strip of material to alternatively elongate and shorten. Thermal cycling over a period of time also trains the alloy to change shape repetitively and accurately with smaller temperature differentials. This device ultimately produces rotary motion, which will be converted into suitable mechanical means for pumping water in absence of conventional electrical power. The outcome of the project is a design of solar pump, which will give a promising solution for a farmer suffering from power shortage problems in summer season. Study has been carried out for device made of stainless steel (SS) also to bring out the figure of merit associated with shape memory alloy compared to SS.

The basic working principle of the proposed design is when two weights are placed on two ends of tube, tube bends with compression on top & tension on bottom and When the temperature of upper portion of tube is increased due to incident radiation, metal in that portion will tend to expand and disrupt the balanced equilibrium conditions with the result being that a torque is developed with in tube which causes the tube to rotate about its axis.

Proposed design consists of a shape memory alloy (Nitinol) which will be connected on either side to two shafts. These shafts will acts as load transport members on which specified bending load will be applied. The other ends of shafts will be terminated in two supports through bearings. Supports will be firmly anchored and the tube rotates along the shafts. Bearings enable the tube to rotate freely with respect to supports.

### 3. DESIGN CALCULATION

It is required to derive expressions for maximum bending stress and thermal efficiency of the proposed design as shown in figure 2. These expressions will be useful during design calculations. This chapter brings out the details of theoretical formulation.

#### 3.1 BENDING STRESS

If the tube is rotating at constant angular velocity  $\omega$ , the stress can be related to moment from simple beam theory

$$\sigma_x = \frac{\text{Bendingmoment}}{\text{Sectionmodulus}} = \frac{M}{Z}$$

$$Z = \frac{\pi}{16D} (2D^2)(2D)\delta = \frac{\pi}{4} (D^2)\delta = \pi R^2 \delta$$

$$\text{Maximum bending stress, } \sigma_{\max} = \frac{M}{\pi R^2 \delta}$$

#### 3.2 THERMAL EFFICIENCY

The tube is free to rotate about X – axis and no moment will be carried by the end supports (Pinned ends) as shown in figure 2.

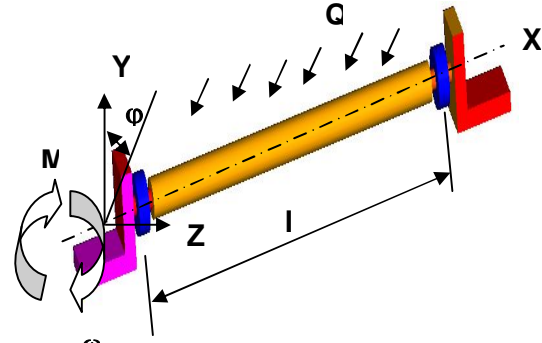

Figure 2: Rotation of Shape memory alloy tube

The thermal power input to the tube is

$$P_1 = 2 \alpha_T Q_0 R l$$

With this thermal efficiency can be expressed as

$$\eta_T = \frac{M_{z0} \alpha \alpha_T Q_0 l}{2 \delta \rho C R 2 \alpha_T Q_0 R l} \sin\left(\psi + \frac{\pi}{2}\right)$$

$$\eta_T = \frac{M_{z0} \alpha l}{4 \delta \rho C R^2} \sin\left(\psi + \frac{\pi}{2}\right)$$

From the expression for maximum bending stress

$$M = \sigma_{\max} \pi R^2 \delta$$

$$\eta_T = \frac{\sigma_{\max} \pi R^2 \delta \alpha}{4 \delta \rho C R^2} \sin\left(\psi + \frac{\pi}{2}\right)$$

From this maximum thermal efficiency becomes Where

$\alpha$  : Coefficient of thermal expansion

$\rho$ : Density

C: Specific heat

#### 4. FE ANALYSIS

Strength based design of the Nitinol is carried out based on the theoretical formulation established in previous chapter. Based on the design calculations dimensions of the tube are arrived. Design calculations are also extended by considering the tube material as stainless steel in order to highlight the figure of merit with nitinol when compared to stainless steel. Then the design is verified through Finite Element Method (FEM). This chapter brings out the details of design calculations along with the dimensional models for both nitinol tube and Stainless Steel (SS) tube and comparison of results.

#### 4.1 DESIGN INPUTS

The following design inputs are considered

- Bending Weights = 98 Kg (Total)
- Desired factor of safety = 1.5
- Yield stress – For nitinol =  $2.3 \times 10^8$  Pa  
For SS =  $3.3 \times 10^8$  Pa

#### 4.2 DESIGN OF NITINOL TUBE

##### Strength Based Design

From the yield stress and desired factor of safety maximum bending stress of the tube is calculated as follows.

$$\text{Desired Factor of safety} = \frac{\text{Yield stress}}{\text{Maximum bending stress}}$$

$$1.5 = \frac{2.3 \times 10^8 \text{ Pa}}{\text{Maximum bending stress}}$$

⇒ Maximum bending stress = 153.33 MPa

An expression for maximum bending moment is obtained from the following diagram with length as variable parameter, as shown in figure 3.

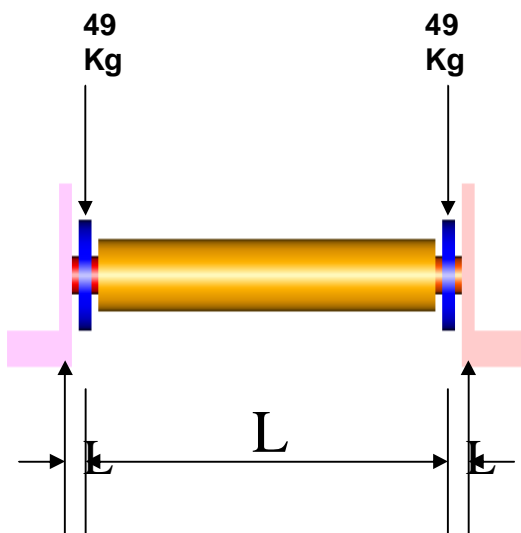

Figure 3: length and variable parameter

Maximum bending moment,  $M = 98 \times 9.81 \times L$

Where L: Length

Using theoretical expression derived for bending stress the dimensions of the tube are obtained as follows.

$$\text{Maximum bending stress, } \sigma_{\max} = 153.33 \text{ MPa} = \frac{M}{\pi R^2 \delta} = \frac{98 \times 9.81 \times L}{\pi R^2 \delta}$$

While satisfying the above expression

$l = 100$  mm

R: Radius of tube = 10 mm

$\delta$ : Thickness of tube = 2 mm

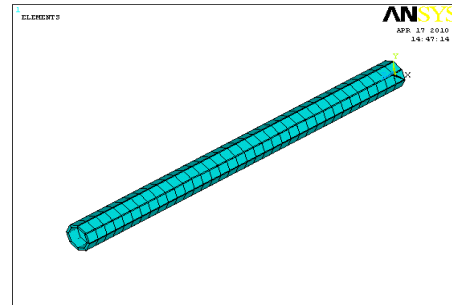

Figure 4: Geometrical and meshed model

Static analysis is done using ANSYS solver and geometrical and meshed model is shown in figure 4, the maximum Von Mises stress is observed to be 158 MPa. And figure 5 shows the Von Mises strain in Nitinol tube.

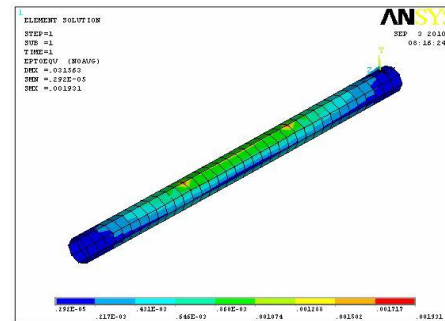

Figure 5: Strain of Nitinol tube

#### 4.3 Thermo Structural Analysis – Nitinol Tube

The same FE model used for structural analysis in previous chapter is also extended for thermo structural analysis. Input radiation power is applied on the top surface of the tube. Input radiation power is calculated using the following relation

$$P_i = 2 \alpha_T Q_0 R l$$

Where

$\alpha_T$ : Thermal diffusivity

$$= \frac{K}{\rho \cdot C_p}$$

In which

K: Thermal conductivity = 18 W/mK

$\rho$ : Density = 6450 Kg/m<sup>3</sup>

$C_p$ : Specific heat = 840 J/KgK

$$\alpha_T = \frac{K}{\rho \cdot C_p} = \frac{18}{6450 \times 840} = 3.3 \times 10^{-6}$$

$Q_0$ : Incident radiant flux =  $7.07 \times 10^{11}$  W/m<sup>2</sup>

R: Radius of tube = 10 mm = 0.01 m

L: Length of tube = 100 mm = 0.1 m

$$\text{Input radiation power} = 2 \times 3.3 \times 10^{-6} \times 7.07 \times 10^{11} \times 0.01 \times 0.1 = 4666.2 \text{ W}$$

After carrying out thermal analysis the temperature distribution thus obtained is taken as load and in addition to this structural bending load is also imposed on the FE model. Then the FE model is solved for thermo structural analysis and angular rotation is obtained as an outcome of the analysis. From analysis the maximum angular rotation is observed to be 0.038 radians. The angular rotation plot is shown in Figure 6.

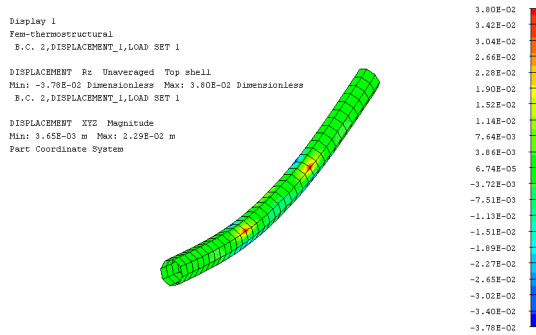

Figure 6: Angular rotation plot of SMA tube

From the angular rotation torque is calculated using following relation.

$$T = \frac{G \theta J}{L}$$

Where

G: Shear modulus =  $3.15 \times 10^{10}$  Pa

$\theta$ : Angular rotation = 0.038 radians

J: Polar moment inertia of the tube =  $9.27 \times 10^{-9}$  m<sup>4</sup>

L: Length of tube = 0.1 m

From the above torque is computed to be 111 N-m.

The thermal efficiency of the proposed design is calculated as follows.

Where

$\alpha$  : Coefficient of thermal expansion =  $6.7 \times 10^{-3}$

$\rho$ : Density = 6450 Kg/m<sup>3</sup>

C: Specific heat = 840 J/KgK

$\sigma_{max}$ : Maximum bending stress = 158 MPa

From the above thermal efficiency is obtained as 15%.

$$\begin{aligned} \text{Output power} &= \text{Input power} \times \text{Thermal efficiency} \\ &= 4666.2 \times 0.15 \\ &= 700 \text{ W} \end{aligned}$$

### 5. RESULTS AND DISCUSSION

The results are segregated into the following three categories for summarizing in design parameters and results.

The results obtained for tube made with nitinol and SS using analytical method and FEM are compared in Table 1, and the graphs are showed in figure 7 to figure 11.

Table 1: Summary of results

Sl. No.	Description	Nitinol	Stainless Steel (SS)
1.	Desired Factor of Safety	1.5	
2.	Yield stress	230 MPa	330 MPa
3.	Maximum bending stress	153.3 MPa (Analytical method) 158 MPa (FEM)	220 MPa (Analytical method) 226 MPa (FEM)
4.	Deformation	0.031563	0.002204
5.	Maximum Strain	0.001931	0.001130
6.	Length	100 mm	50 mm
7.	Radius	10 mm	5.89 mm
8.	Thickness	2 mm	
9.	Angular rotation	0.038 radians	0.0178 radians
10.	Driving torque	111 N-m	30 N-m
11.	Thermal efficiency	15 %	3 %
12.	Output power	700 W	50 W

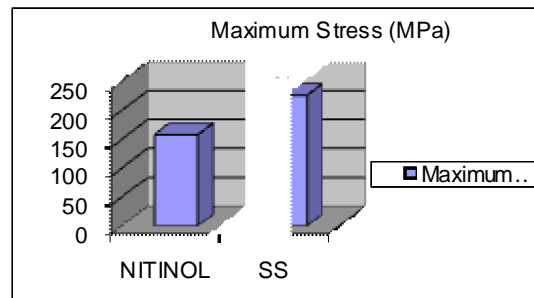

Figure 7: Stresses developed in both the materials

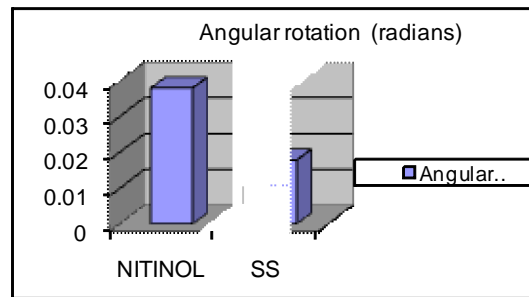

Figure 8: Angular of rotation for steel and shape memory alloy

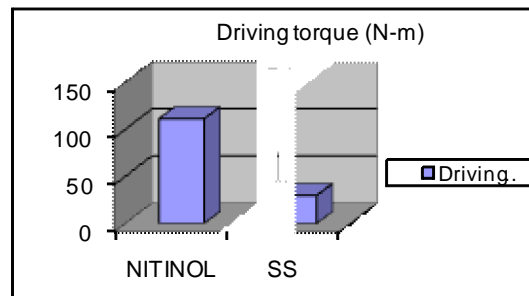
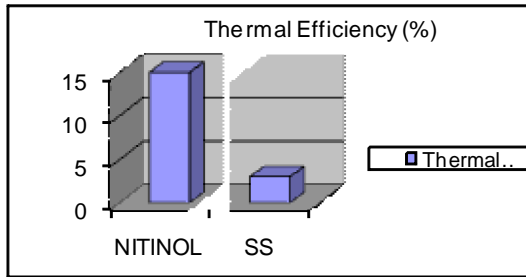
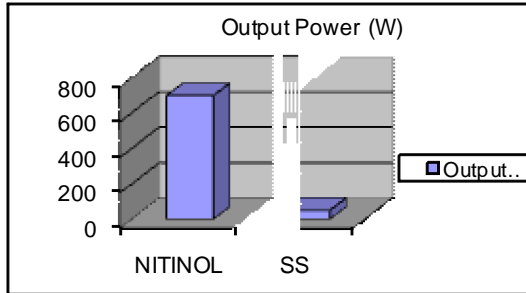

Figure 9: Drive torque developed in both steel and SMA



**Figure 10:** Thermal efficiency of the both Nitinol and Steel tubes



**Figure 11:** Output power of the Nitinol tube and Steel tube

## 6. CONCLUSION

This project is taken up in the upcoming area i.e. shape memory alloys. A low cost solar pump based on shape memory alloy is designed which can be comfortably procured by a farmer for meeting water pumping requirements during electrical power shutdown. As an outcome of the project an analytical method is established to design the tube and to calculate the thermal efficiency. In order to highlight the figure of merit associated with nitinol, study is extended for stainless steel also. During the design the dimensional parameters like length, radius and thickness are carefully chosen to achieve compromise between higher value of bending stress for achieving maximum possible thermal efficiency and the constraint from factor of safety point of view seeking for limiting the bending stress. Proposed analytical method is validated with Finite Element Method (FEM).

## REFERENCES

- [1]. J. Uchil, K.K. Mahesh, K. Ganesh Kumara, Calorimetric study of the effect of linear strain on the shape memory properties of Nitinol, 2001
- [2]. D. Favier Y. Liu L. Org' eas A. Sandel L. Debove, P. Comte-Gazcin Influence of Thermo mechanical processing on the super elastic properties of a Ni-rich Nitinol shape memory alloy, 2006
- [3]. Brian Lin a, Ken Gall, Hans J. Maier c, Robbie Waldron, Structure and thermo mechanical behavior of NiTiPt shape memory alloy wires, 2008
- [4]. R. DesRoches, M. Delemont, Seismic retrofit of simply supported bridges using shape memory alloys, 2002
- [5]. G. Costanza, M.E. Tata, C. Calisti, Nitinol one-way shape memory springs: Thermo mechanical characterization and actuator design, 2009
- [6]. Xin-Yan Tsai, Lien-Wen Chen, Dynamic stability of a shape memory alloy wireReinforced composite beam, 2004.
- [7]. J.M. McNaney, V. Imbeni, Y. Jung, Panayiotis Papadopoulos, R.O. Ritchie An experimental study of the super elastic affecting a shape-memory Nitinol alloy Under biaxial loading, 2002
- [8]. P. Tautzenberger ana D. Stockel G. RAU, The use of shape memory alloys in switch gear technology, 2004
- [9]. Ridgway M. Banks, An experimental study on continuously operating heat engine that uses SMA, 2001
- [10]. Dr. Johnson, the VT1 Shape Memory Alloy Heat Engine Design, 2002
- [11]. John J. Pachte, An experimental study on heat engine using SMA belts, 2001