

## **WIRELESS SENSORS BASED DATA ACQUISITION SYSTEM USING SMART MOBILE APPLICATION**



**BHAVANA GODAVARTHI<sup>1</sup>, PAPA RAO NALAJALA<sup>2</sup>, M LAKSHMI RAVI TEJA<sup>3</sup>**

Asst. Professor, Dept. of Electronics & Communication Engineering at Institute of Aeronautical Engineering, [Bhavana.bhanu402@gmail.com](mailto:Bhavana.bhanu402@gmail.com)

Asst. Professor, Dept. of Electronics & Communication Engineering at Institute of Aeronautical Engineering, [nprece@gmail.com](mailto:nprece@gmail.com)

Asst. Professor, Dept. of Electronics & Communication Engineering at Institute of Aeronautical Engineering, [Lakshmi.ravi3003@gmail.com](mailto:Lakshmi.ravi3003@gmail.com)

**Abstract:** The scope of this project is to develop a sensor interface device essential for sensor data collection of industrial environment

We manually measure physical parameters in the industry like temperature, humidity, water level, CO<sub>2</sub>, moisture sensor and light detection which is very difficult and inaccurate. A normal person cannot measure the physical parameters accurately. To avoid this difficulty we are going for our proposed system where the wireless connection is implemented to acquire data from the various sensors, in addition it reduces set up difficulties. By using Bluetooth Technology, sensors data is sent to the authorized person, who can see the data status on smart phone through Android Application.

The project is aimed to design a security system which can monitor the different sensors to acquire Industrial parameters like smoke and temperature and transmit the data to the authorized person using Bluetooth communication technology. The major advantage of this PROJECT is providing the security for data while transmitting and sensing the sensor Values very accurately.

**Keywords:** ARM7 (LPC2148), Sensor Data acquisition, Bluetooth Device, LCD Display

### **INTRODUCTION**

Wireless Sensor has been employed to collect data about physical phenomena in various applications such as habitat monitoring, and ocean monitoring, and surveillance. As an emerging technology brought about rapid advances in modern wireless telecommunication. Wireless sensor has attracted a lot of attention and is expected to bring benefits to numerous application areas including industrial WSN systems, and healthcare systems manufacturing. Wireless sensors systems are well-suited for long-term industrial. Environmental data acquisition representation. Sensor interface device is essential for detecting various kinds of sensor data of industrial environments. It enables us to acquire sensor data. Thus, we can better understand the outside environment information. However, in order to meet the requirements of long-term industrial environmental data acquisition in the sensors, the acquisition interface

device can collect multiple sensor data at the same time, so that more accurate and diverse data information can be collected from industrial wireless sensors.

Bluetooth modules are designed with low to medium transmit power and for high reliability wireless networks. The modules require minimal power and provide reliable delivery of data between devices. The interfaces provided with the module help to directly fit into many industrial applications. The modules operate within the ISM 2.4-2.4835 GHz frequency band with IEEE 802.15.4 baseband. Power of Bluetooth module is up to 100mW and its sensitivity is  $\leq -84\text{dBm}$  at 0.1% BER.

The project is designed in such a way that one Bluetooth transceiver will be interfaced to the ARM through receiver and transmitter pins. The Bluetooth transceiver is used to encode the data received from sensor network. One end of sensor network is connected with Controller and to transmit the data. Hence the encoded data will be transmitted by the Bluetooth transceiver over the wireless medium and the data will be received by the authorized user through Bluetooth application in an android mobile. Now it is the responsibility of the controller to sense and transfer sensor values of smoke and temperature sensor's values continuously.

This project uses regulated 1.3-3.3V, 1A power supply. 7805 three terminal voltage regulator is used for voltage regulation. Full wave bridge rectifier is used to rectify the ac output of secondary of 230/12V step down transformer.

### **IMPLEMENTATION**

The overall structure of reconfigurable smart sensor interface consists of CPLD chip (XC2C256 chip), crystals and peripheral circuit, communication circuit for turning USB to serial port (PL2303HXC chips and peripheral circuits), power supply of 1.8 and 3.3 V (LM1117 chip, voltage regulator and filter circuit), an SRAM memory (TC55V400 chip), high-speed 8-channel ADC (ADS7870 chip and peripheral circuit), LED

indicator light, an analog extended interface, and three digital extended interfaces. Every extended interface among them can connect eight independent sensors, namely, the reconfigurable smart sensor interface device can access eight analog signals and 24 digital signals.

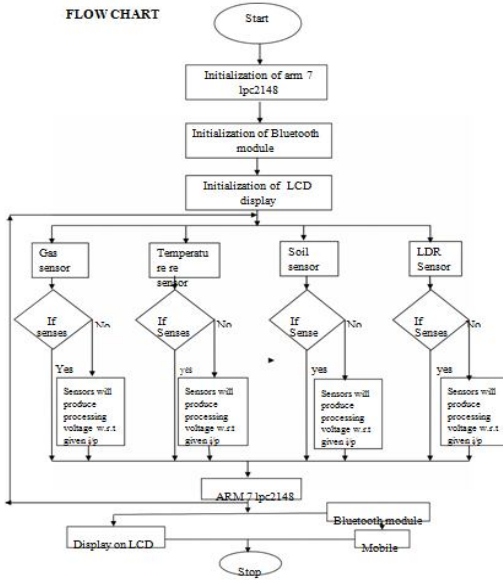

Fig: 1 Design and Implementation

**PROBLEM IDENTIFICATION**

Disadvantages, such as bulkiness, complex design, and high cost, etc. It is not suitable for monitoring conducted by small organizations or individual. In terms of water quality monitoring, it mainly involves the following aspects.

- 1) We can monitor water purity, internal and external water temperature, carbon dioxide concentration and light intensity on the surface of water in real time.
- 2) Multiple nodes are distributed in different areas of pond.
- 3) Low power battery provides power for the system.

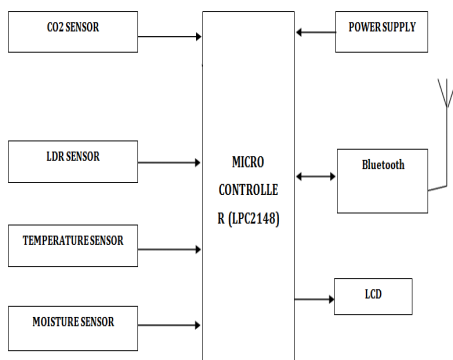

Fig: 1.2 Hardware Block Diagram

ARM is a 32-bit reduced instruction set computer (RISC) instruction set architecture (ISA) developed by ARM Holdings. It was named the Advanced RISC Machine and, before that, the Acorn RISC Machine. The ARM architecture is the most widely used 32-bit instruction set architecture in numbers produced Originally conceived by Acorn Computers for use in its personal computers, the first ARM-based products were the Acorn Archimedes range introduced in 1987.T.I, Philips, Intel, RISC microcontroller.

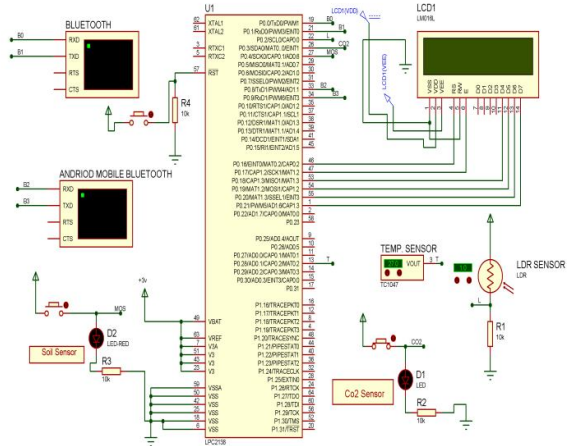

Fig: 1.3 Application and working Diagram of Wireless sensors based data acquisition system using smart mobile

**WIRELESS SENSORS**

A sensor (also called detectors) is a device that measures a measurable attribute and converts it into a signal which can be read by an observer or by an instrument. For example, a mercury-in-glass thermometer converts the measured temperature into expansion and contraction of a liquid which can be read on a calibrated glass tube. A thermocouple converts temperature to an output voltage which can be read by a voltmeter.

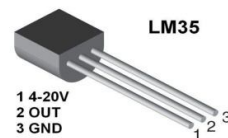
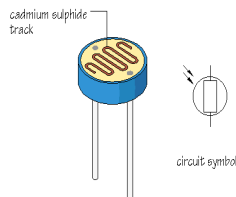

Fig: 2 Temperature Sensors

Temperature Sensor which converts temperature value into electrical signals. We used IC called LM 35 as a temperature sensor. LM35 series sensors are precision integrated-circuit temperature sensors whose output voltage is linearly proportional to the Celsius temperature. The LM35 requires no external calibration since it is internally calibrated. The LM35 does not require any external calibration or trimming to provide typical accuracies of  $\pm 1/4^{\circ}\text{C}$  at room temperature and

The LM35's low output impedance, linear output, and precise inherent calibration make interfacing to readout or control circuitry especially easy. It can be used with single power supplies, or with plus and minus supplies. As it draws only 60  $\mu$ A from its supply, it has very low self-heating, less than 0.1°C in still air



**Fig: 2.1 Light Dependent Resistors (LDR)**

A photo resistor or Light Dependent Resistor or CD's Cell is a resistor whose resistance decreases with increasing incident light intensity. It can also be referred to as a photoconductor. A photo resistor is made of a high resistance semiconductor. If light falling on the device is of high enough frequency, photons absorbed by the semiconductor give bound electrons enough energy to jump into the conduction band. The resulting free electron (and its hole partner) conduct electricity, thereby lowering resistance.



**Fig: 2.2 Co2 Sensors**

A carbon dioxide sensor or CO<sub>2</sub> sensor is an instrument for the measurement of carbon dioxide gas. The most common principles for CO<sub>2</sub> sensors are infrared gas sensors (NDIR) and chemical gas sensors. Measuring carbon dioxide is important in monitoring indoor air quality, the function of the lungs in the form of a cap no graph device, and many industrial processes.

Chemical CO<sub>2</sub> gas sensors with sensitive layers based on polymer- or heteropolysiloxane have the principal advantage of very low energy consumption, and can be reduced in size to fit into microelectronic-based systems. On the downside, short- and long term drift effects as well as a rather low overall lifetime are major obstacles when compared with the NDIR measurement principle. Most CO<sub>2</sub> sensors are fully calibrated prior to shipping from the factory. Over time, the zero point of the sensor needs to be calibrated to maintain the long term stability of the sensor

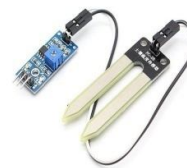

**Fig: 2.3 Soil Sensors**

Soil moisture and is used for remote sensing in hydrology and agriculture. Portable probe instruments are used by farmers or gardeners. Soil moisture sensors measure the water content in soil. A soil moisture probe is made up of multiple soil moisture sensors. Since analytical measurement of free soil moisture requires removing a sample and drying it to extract moisture, soil moisture sensors measure some other property, such as electrical resistance, dielectric constant, or interaction with neutrons, as a proxy for moisture content. The relation between the measured property and soil moisture must be calibrated and may vary depending on soil type. Reflected microwave radiation is affected by the

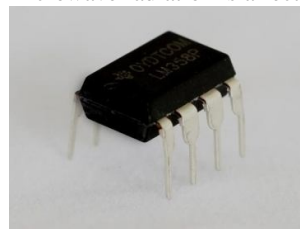

**Fig: 2.4 LM358**

The LM358 is a general purpose op-amp with 2 channels. Applications include transducer amplifiers, dc amplification blocks, and all the conventional operational amplifier circuits that now can be implemented more easily in single-supply-voltage systems. For example, these devices can be operated directly from the standard 5-V supply used in digital systems and easily can provide the required interface electronics without additional  $\pm 5$ -V supplies.

### LCD COMMANDS

To send any command to the LCD, make pin RS=0 (i.e., command writing from microcontroller to LCD). For data, make RS=1 (i.e., data writing from microcontroller to LCD). Then place a high to low pulse on the E pin to enable the internal latch of the LCD. All commands like 0x38, 0x28... are stored in command register, whatever the data we want to display on LCD is stored on data register.

## RESULT

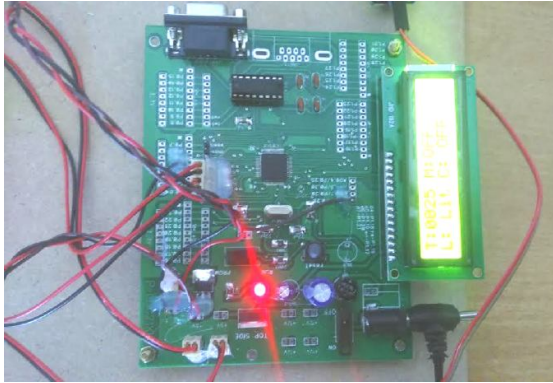

**Fig: 2.4 Bluetooth HC-05 Modules**

Bluetooth is an open wireless technology standard for exchanging data over short distances (using short wavelength radio transmissions) from fixed and mobile devices, creating personal area networks (PANs) with high levels of security. Created by telecoms vendor Ericsson in 1994 it was originally conceived as a wireless alternative to RS-232 data cables. It can connect several devices, overcoming problems of synchronization.

## SIMULATOR/DEBUGGER

The simulator/ debugger in KEIL can perform a very detailed simulation of a micro controller along with external signals. It is possible to view the precise execution time of a single assembly instruction, or a single line of C code, all the way up to the entire application, simply by entering the crystal frequency. A window can be opened for each peripheral on the device, showing the state of the peripheral. This enables quick trouble shooting of mis-configured peripherals. Breakpoints may be set on either assembly instructions or lines of C code, and execution may be stepped through one instruction or C line at a time. The contents of all the memory areas may be viewed along with ability to find specific variables. In addition the registers may be viewed allowing a detailed view of what the microcontroller is doing at any point in time.

## Conclusion:

This paper describes a Wireless smart sensor interface for industrial. The system can collect sensor data intelligently. It was designed based on application of wireless communication. It is very suitable for real-time and effective requirements of the high- speed data acquisition system. The system to collect sensor data intelligently. Different types of sensors can be used as long as they are connected to the system. Main design method of the Wireless smart sensor interface device is described in this paper. Finally, by taking real- time monitoring of water environment as an example, we verified that the system achieved good effects in practical application.

Nevertheless, many interesting directions are remaining for further researches. For example, the IEEE1451 protocol can be perfected and the function of spreadsheet should be expanded. It will have a broad space for development in the area of Wireless sensors

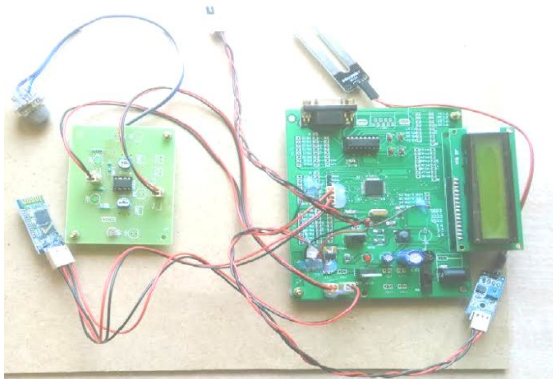

**Fig: 3** System developed interface wireless sensors with ARM7 and interface Wireless Bluetooth

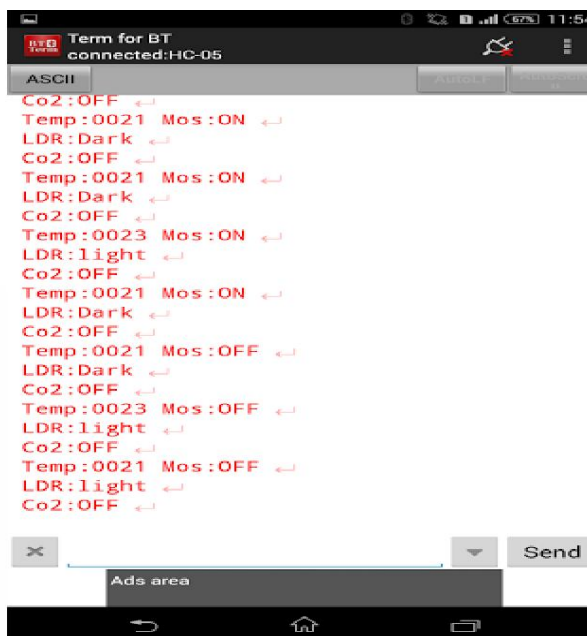

**Fig: 3.1** Displayed data on mobile phone through Bluetooth and mobile application

## REFERENCES

- [1] S. Li, L. Xu, X. Wang, and J. Wang, "Integration of hybrid wireless networks in cloud services oriented enterprise information systems," *Enterp. Inf. Syst.*, vol. 6, no. 2, pp. 165–187, 2012.
- [2] Q. Li, Z. Wang, W. Li, J. Li, C. Wang, and R. Du, "Applications integration in a hybrid cloud computing environment: Modelling and platform," *Enterp. Inf. Syst.*, vol. 7, no. 3, pp. 237–271, 2013.
- [3] L. Wang, L. D. Xu, Z. Bi, and Y. Xu, "Data cleaning for RFID and WSN integration," *IEEE Trans. Ind. Informat.*, vol. 10, no. 1, pp. 408–418, Feb. 2014.
- [4] Y. Fan, Y. Yin, L. Xu, Y. Zeng, and F. Wu, "IoT based smart rehabilitation system," *IEEE Trans. Ind. Informat.*, vol. 10, no. 2, pp. 1568–1577, 2014.
- [5] W. He, G. Yan, and L. Xu, "Developing vehicular data cloud services in the IoT environment," *IEEE Trans. Ind. Informat.*, vol. 10, no. 2, pp. 1587–1595, 2014.
- [6] M. T. Lazarescu, "Design of a WSN platform for long-term environmental monitoring for IoT applications," *IEEE J. Emerg. Sel. Topics Circuits Syst.*, vol. 3, no. 1, pp. 45–54, Mar. 2013.
- [7] L. Xu, "Introduction: systems science in industrial sectors," *Syst. Res. Behav. Sci.*, vol. 30, no. 3, pp. 211–213, 2013.
- [8] Z. Pang *et al.*, "Ecosystem analysis in the design of open platform-based in-home healthcare terminals towards the internet-of-things," in *Proc. IEEE 15th Int. Conf. Adv. Commun. Technol. (ICACT)*, 2013, pp. 529–534.
- [9] L. Benini, "Designing next-generation smart sensor hubs for the Internet- of-Things," in *Proc. 5th IEEE Int. Workshop Adv. Sensors Interfaces (IWASI)*, 2013, p. 113.
- [10] Y. Chen and V. Dinavahi, "Multi-FPGA digital hardware design for detailed large-scale real-time electromagnetic transient simulation of power systems," *IET Gener. Transmiss. Distrib.*, vol. 7, no. 5, pp. 451–463, 2013.
- [11] A. Myaing and V. Dinavahi, "FPGA-based real-time emulation of power electronic systems with detailed representation of device characteristics," *IEEE Trans. Ind. Electron.*, vol. 58, no. 1, pp. 358–368, Jan. 2011.
- [12] R. Dafali, J. Diguët, and J. Creput, "Self-adaptive network-on-chip interface," *IEEE Embedded Syst. Lett.*, vol. 5, no. 4, pp. 73–76, Dec. 2013.
- [13] J. H.-L. Lu *et al.*, "A low-power, wide-dynamic-range semi-digital universal sensor readout

circuit using pulsewidth modulation," *IEEE Sensors J.*, vol. 11, no. 5, pp. 1134–1144, May 2011.

[14] Z. Pang *et al.*, "An RTOS-based architecture for industrial wireless sensor network stacks with multi-processor support," in *Proc. Ind. Technol. (ICIT)*, 2013, pp. 1216–1221.

## Authors Biography

1.



Bhavana G, Working as Asst. Professor in the Dept. of ECE at IARE, Hyderabad. 5 years Experience in relative field. She research interests includes Embedded systems Image processing and Communications

2.



Papa Rao N Working as Asst. Professor in the Dept. of ECE at IARE, Hyderabad. 5 years Experience in Teaching and 2 Years in Research. His research interests includes Embedded systems, Image processing, Communications and Wireless sensor networks

3.



M Lakshmi Ravi Teja, Completed M.Tech in VIT. Working as Asst. Professor in the Dept. of ECE at IARE, Hyderabad. His research interests includes Embedded systems, Sensors